



PDG 3000

230V / 460V

PLANETARY

EDGER



SASE Company, Inc.
Phone 800.522.2606 or Fax
877.762.0748
www.SASECompany.com

Version 2.2
12/23/2020



Corporate Office Details
26423 79th Ave South
Kent, WA 98032-7321
1.800.522.2606 (P)
1.877.762.0748 (F)
www.SASECompany.com
sales@SASECompany.com

Congratulations on your decision to get the Power of SASE behind you! SASE is committed to excellence, excellence in the quality of products we sell and excellence in service and support after the sale. It is important to us that your business continues to succeed and grow, and we know that the right products, service and support can have a great impact on your bottom line.

SASE has made great strides in the concrete preparation and polishing industry over the years. With a 40,000 square foot distribution and service facility in Seattle, a 22,000 square foot distribution and service facility in Knoxville, and local sales and technical support representatives throughout the United States, SASE is able to provide unsurpassed service and technical support for the contractor.

At SASE we engineer and manufacture our own equipment, which allows us to be in control of the quality of the equipment we sell. SASE offers a complete line of concrete preparation and polishing equipment, our newest introduction being our new line of PDG planetary diamond grinders, which is setting a new standard for the concrete grinding and polishing industry. SASE is also the leader in diamond tooling technology.

We look forward to a long and prosperous partnership with you! Thank you again for choosing SASE. You won't regret having the Power of SASE behind your company!

Sincerely,
SASE Company, Inc.

Jim Weder

President

Introduction

The SASE PDG 3000 planetary diamond grinder is designed to grind edges and under toe kicks. Their applications range from rough grinding through to a polished finish.

It is extremely important all users be familiar with the contents of this manual before commencing operation of either machine. Failure to do so may result in damage to machinery or expose operator to unnecessary dangers.

IMPORTANT

Only staff that has received the necessary training, both practically and theoretically concerning their usage should operate the machinery.

Mechanical Action of Moving Machine Parts

Several parts of this machine are understood to be dangerous.

The Grind Head has a rotation and a counter rotation, keep body parts clear of the moving grinder head.

The handle is heavy. Failure to lock the handle in place can result in operator injury.

During operation, the machine has a twisting force. If you lose control of the machine, it will walk away without you. The operator has to maintain control of the machine. The machine moving freely can damage finished floor sections, or wall sections. Not to mention anyone caught by the grind head could be seriously injured.

Preventative Maintenance

Preventing the hazard is the best case scenario. Preventative Maintenance (PM) is the responsibility of the operator.

- ❖ Check and clean air filter regularly(200 operating hours)
- ❖ Keep a Log Book for all service done.
- ❖ Be sure that adequate vacuum system is in use.
- ❖ Be aware of changes in operation, smell, noise, etc. while operating
- ❖ Report to management ANY safety concerns.
- ❖ Follow manufacturer recommendations for all motor maintenance.

Storage

The machine should always be stored in a cool, dry location. Moisture may upset fragile electrical components.

Break-Down

The machine can be divided into two main parts.

1. Chassis/Frame section – This comprises the handle bars, body panels, Steel frame and wheel assembly.
2. Drum/Head – this comprises the motor, cover, grinding/satellite/ planetary heads and internal components

The machine has been manufactured to allow movement between the chassis and head via the connection point. This movement is important during the grinding process as it creates a “floating” effect for the head. The floating gives the head a self leveling effect, negating the need to adjust the height of the

head as the machine passes over floor areas with different slopes or undulations.

Set-Up

Position the grinder in the working area. Make sure there are diamonds underneath the machine, and that the head locks are tight.

IMPORTANT

Planetary head and grinding heads are set to turn in opposite directions of each other.(as shown in this depiction)



- ❖ **When using the machine, each grinding head must always have the same diamond type and number of diamonds as the other heads.**
- ❖ Each diamond must also be the same height as the next.
- ❖ The skirt must be adjusted so that a good seal is established, between the floor and the grind head.

When setting the height of the handle, the operator is the guide. The comfort of the operator during grinding is key. The handlebar should rest right at the operator's hip bone. When the machine is running, there will be a grinding force to one side that can be felt through the handlebars. Use the hip to resist this force instead of the arms.

Control Panel

The control panel consists of 2 switches, a knob, and a button.



LEFT	Switch controls rotation of the drum in the 'reverse' direction. *Will not work if inverter is in fault
RIGHT	Switch controls rotation of the drum in the 'forward' direction. *Will not work if inverter is in fault
This switch has a 'null' position, in the middle. Acting as a stop. Giving neither forward or reverse direction.	
STOP	Turn switch to stop, to get rotation to stop. If the machine faults during operation, turn the dial to stop before resetting.
RUN	Turn switch to run, to get rotation to start. *Will not work if inverter is in fault
SPEED	Controls the speed of rotation and counter rotation simultaneously. Range: Low 0 to High 10
START/RESET	Button push sends a reset signal. To start the first time, the machine requires a reset signal.
RESET	To start after a fault, the machine requires a reset signal.
Turn the stop/run switch to the <u>STOP</u> position to prevent uncontrolled start at reset	

Determining Diamond Selection

Proper diamond selection is one of the most important step in creating the perfect floor finish.

Diamond Background

Diamond abrasives usually consist of 2 components:

- ❖ Diamond powder (also known as diamond crystals or grit). By changing the size of the diamond powder or grit, we can change how coarse or fine the scratches will be that are left behind from the grinding process.
- ❖ A binding agent (metal or resin). Diamond powder is mixed and suspended in either a metal or resin binding agent. When suspended in a metal bond matrix, the finished product is referred to as a Metal Bond or Sintered diamond segment. When suspended in a resin bond matrix, the finished product is referred to as a Resin Bond diamond segment or pad.

General Diamond Principles

Diamond Grit Size:

Changing the size of the diamond grit to a smaller particle/ grit size will affect the performance of the diamond tool in the following ways:

- ❖ Create a finer scratch pattern.
- ❖ Increase the life of the diamond tool.

The opposite will occur when changing to a larger particle/grit size.

The Binding Agent/Metal Bond or Resin Bond:

Increasing hardness of bond will

- ❖ Increase life of diamond tool.
- ❖ Decrease production rate.
- ❖ Cause diamond tool to leave finer scratches in dry – grinding applications (when compared to a softer bond diamond tool with the same diamond grit size).
- ❖ A hard bond matrix should be used on a soft floor and a soft bond matrix should be used on a hard floor.

Grinding disc set-up:

The set-up of diamond segments on the grinding heads of the machine will influence the performance of the machine, the productivity levels and also the finished floor quality.

Changing of Diamonds

Different applications often require different selections of diamond tooling. There will be many occasions when the grinding discs need to be changed.

Following is a guide for this procedure.

Preparation

Press the Stop button and engage the Emergency Stop button. As an extra precaution, you can unplug the power cord.

Change

1. Set handle in upright position.
2. Pull back on handle to lift grinding head off the ground (Above Top).
3. Lay machine back on the ground
4. Put on gloves.
5. Remove grinding disc from flex plate.
6. Check to ensure that all discs are secure.
7. Once new diamonds have been attached, reverse procedure to lower machine to ground.



As new diamonds may be a different height than the set being previously used, re-adjust skirt to ensure good seal is established with the floor.

Personal Safety



Please read the operator's manual carefully and make sure you understand the instructions before using the machine.



WARNING! Dust forms when grinding which can cause injuries if inhaled. Use an approved breathing mask. Always provide for good ventilation while machine is in use.

Always wear approved PPE:



Protective helmet



Hearing protection



Dust Mask



Protective goggles



Non-slip boots with steel toe



Protective gloves

WARNING

Under no circumstances may the machine be started without observing the safety instructions.

Should the user fail to comply with these suggestions, SASE Company Inc. or its representatives are free from all liability both directly and indirectly.

Read through these instructions and make sure that you understand the contents before starting to use the machine.

Should you, after reading the safety instructions, still feel uncertain about the safety risks involved you must not use the machine, please contact your SASE representative for more information.

Reminder

- ❖ Always check electrical source before starting.
- ❖ Only qualified personnel should be allowed to operate machinery.
- ❖ Never use a machine that is faulty. Carry out the checks, maintenance and service instructions described in this manual. All repairs not covered in this manual must be performed by a repairer nominated by either the manufacturer or distributor.
- ❖ Always wear personal safety equipment such as sturdy non-slip boots, ear protection, dust mask and approved eye protection.
- ❖ Machinery should only be started when grinding heads are resting on the ground.
- ❖ The machine should not be started without the dust skirt attached. It is essential a good seal between floor and machine be established for safety, especially when operating in dry grinding applications.
- ❖ When changing the grinding discs ensure the unit is OFF. Press the Stop button and when the machine is completely stopped, press the emergency stop button. Disconnect the power cord, to add protection.
- ❖ The machine should not be lifted by handles, motor, chassis or other parts. Transportation of the machine is best done on a pallet / skid to which the machine must be firmly secured.
- ❖ Extreme caution must be used when moving machinery by hand on an inclined plane. Even the slightest slope can cause forces/ momentum making the machinery impossible to brake manually.
- ❖ Never use the machine if you are tired, if you have consumed any alcohol, or if you are taking medication that could affect your vision, your judgment or your coordination.
- ❖ Never use a machine that has been modified in any way from its original specification.
- ❖ Be on your guard for electrical shocks. Avoid having body contact with lightning conductors/metal in the ground.

Transportation

The machine comes equipped with an electronic system called a variable speed drive or a frequency converter. The drive enables the variable speed and direction component of the motor.

The drive is located in the steel cabinet mounted on the machine chassis. As with all electronic equipment, the drives are sensitive to excessive vibration, rough treatment and high levels of dust. Much care and attention has been given by SASE to ensure maximum protection is given to the drive.

When transporting, it is important to ensure the machinery is properly secured at all times to eliminate "bouncing". Ensure the chassis or frame section of the machine is secured down at all times when in transit.

The machine should always be transported under cover limiting the exposure to natural elements – in particular rain and snow. The machine should not be lifted by handle, motor, chassis or other parts.

Transportation of the machine is best done on a pallet/skid to which the machine must be firmly secured. Do not attempt to slide the tines/forks from a fork lift under grinding heads unless on a pallet/skid. Failure to do so can cause extreme damage to grinding heads of machine and internal parts.

Speed

The grinding speed should start low and increase as the operator becomes more comfortable with the application. Be sure that the RPM's do not exceed 2000 when starting and stopping the drum rotation. The machine should be running and the drum rotating before speed selection is fine tuned.

Safety Hazards

Before using the equipment, inspect electrical lines, and connections. Make sure the machine is in good working order. Electrical shock from a split wire could be fatal.

- ❖ Check that the cord and extension cord are intact and in good condition.
- ❖ Never use the machine if the cord is damaged, hand it in to an authorized service workshop for repair.
- ❖ Do not use a rolled up extension cord.
- ❖ Electrical cords must not exceed 200ft in length.
- ❖ The machine should be connected to an earthed outlet socket.
- ❖ Check that the mains voltage corresponds with that stated on the rating plate on the machine.
- ❖ Ensure the cord is behind you when you start to use the machine so that the cord will not be damaged.



Inspection and/or maintenance should be carried out with the motor switched off and the plug disconnected.



WARNING - HIGH VOLTAGE!

8

7

6

5

4

3

2

1

D

C

B

A

D

C

B

A

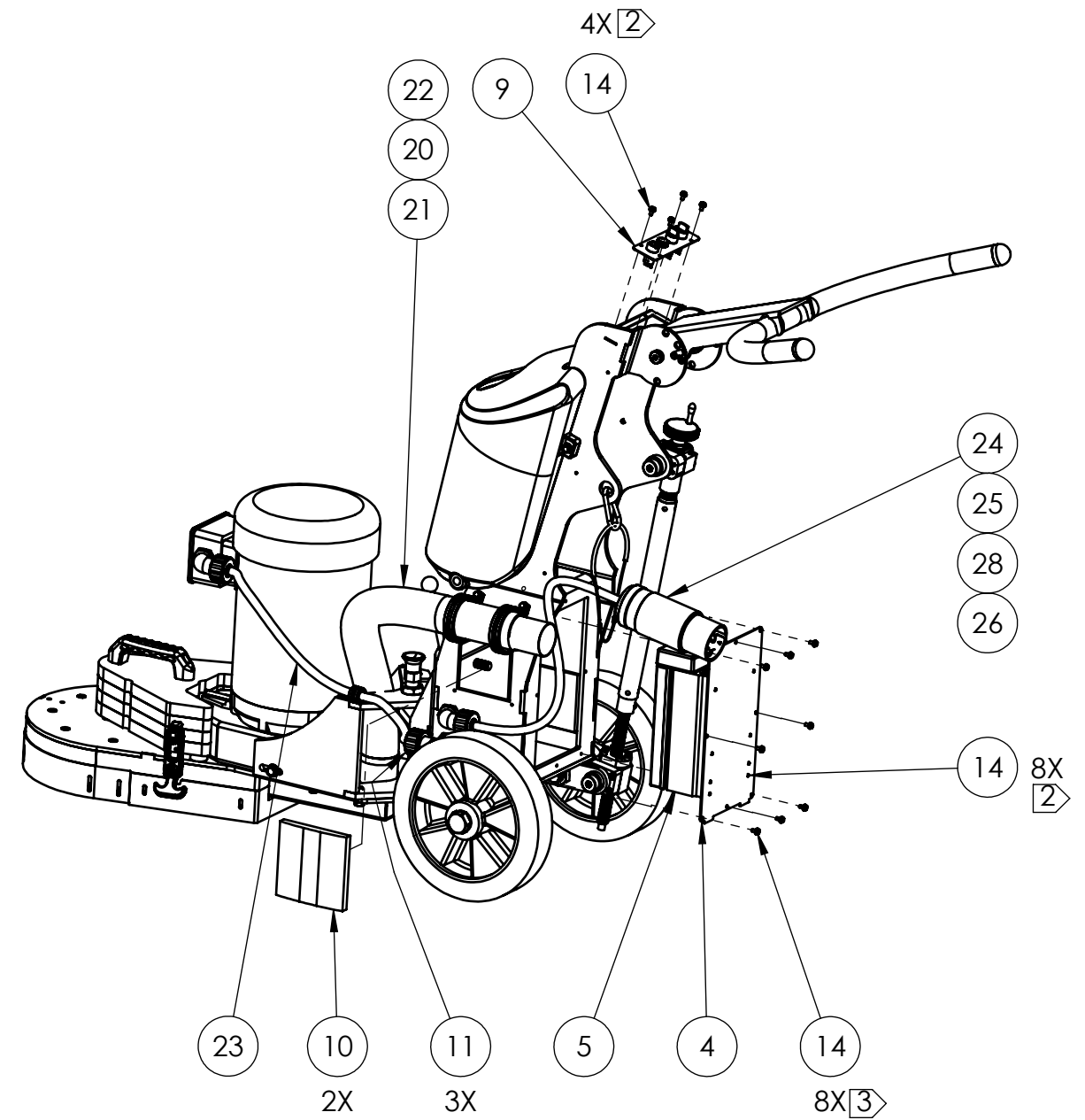
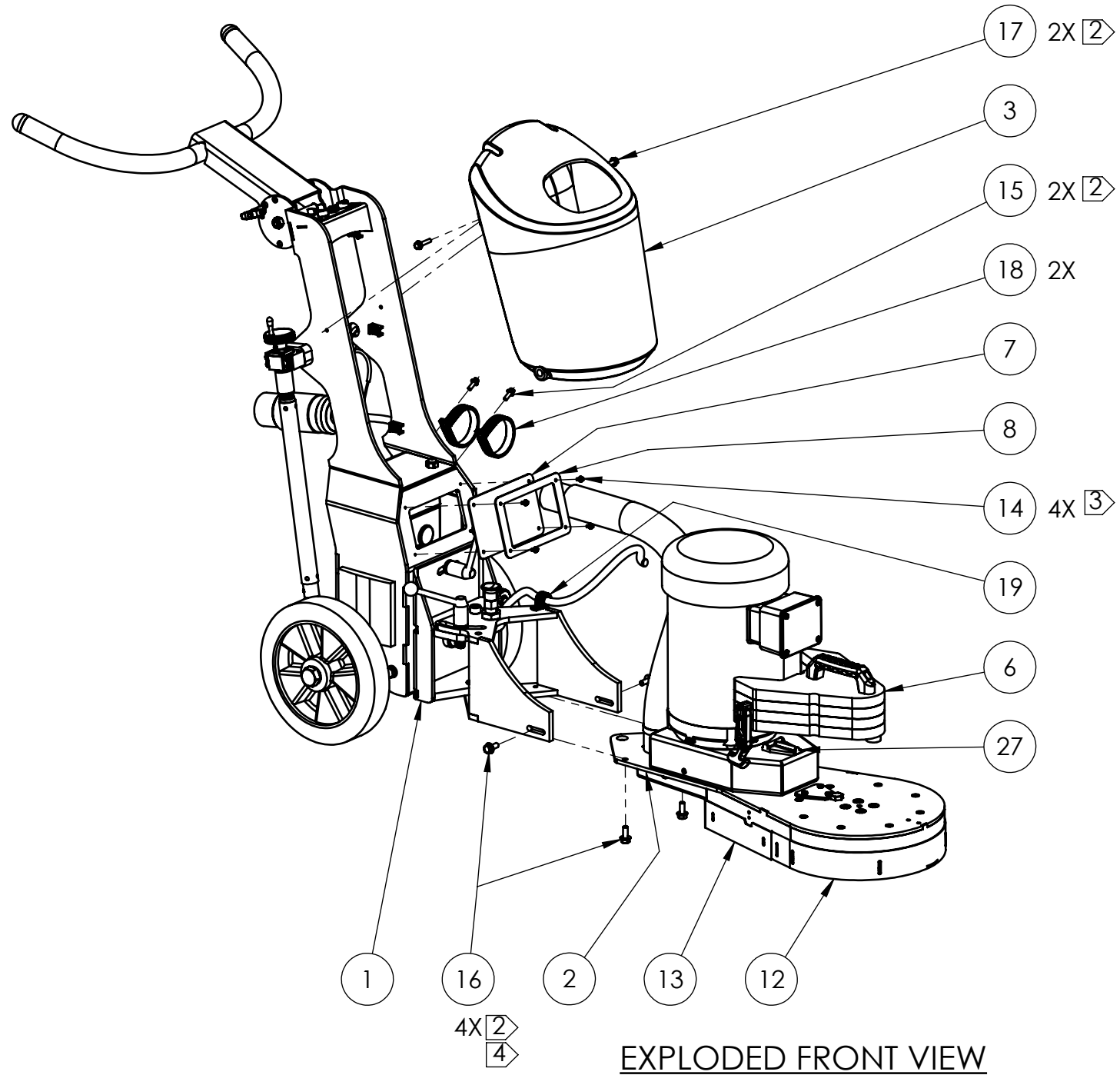

NOTES:

- 1. SEE SHEET 2 FOR EXPLODED VIEW AND ITEM BUBBLES.
- [2] APPLY THREAD LOCKER (RED LOCTITE #263).
- [3] APPLY THREAD LOCKER (BLUE LOCTITE #243).
- [4] APPLY TORQUE TO 30 FT-LBS.

P/N: PDG.33000.00

SASE COMPANY, LLC
 26423 79TH AVE S, KENT, WA 98032

TITLE:

PDG 3K FINAL

8

7

6

5

4

3

2

1

PDG3000 FINAL

Item No.	Part No.	Description	Qty.
1	PDG.33001.10	PDG 3K EDGER FRAME SUBASSEMBLY	1
2	SEE PAGE	3K EDGER FRONT END ASSEMBLY	1
3	PDG.45059.00	TANK	1
4	PDG.33010.00	PDG 3K EDGER INVERTER COVER	1
5	PDG.30045.00	INVERTER KBVF-45	1
6	PDG.32030.01	PLANETARY EDGER WEIGHT ASSEMBLY	1
7	PDG.33014.00	INVERTER WINDOW	1
8	PDG.33013.00	WINDOW FRAME	1
9	PDG.32100.00	PLANETARY EDGER INSTRUMENT PANEL	1
10	PDG.50120.00	COVER, VENT HOLE	2
11	NB.59.101	90 MALE GRIP CORD	3
12	PDG.32107.00	SHROUD, FORWARD	1
13	PDG.32108.00	SHROUD, REAR	1
14	NB.11.107	SCREW, FLANGED SOCKET HEAD CAP M4-0.7 X 8 ZINC	24
15	NB.11.108	SCREW, HEX FLANGED M6 X 16	2
16	NB.11.123	SCREW, FLANGED HEX HEAD CAP M8-1.25 X 20 NON-SERRATED ZINC	4
17	NB.11.112	SCREW, FLANGED HEX HEAD CAP M6-1.0 X 30 NON-SERRATED ZINC	2
18	NB.52.202	CLAMP, LOOP 3/4" WIDE, 2-1/2"	2
19	NB.52.204	CLAMP, LOOP 3/4" ID 1/2" WIDE	1
20	VAC.WCN2.020	CONNECTOR, HOSE COUPLER	1
21	WVACH200000	2" VACCUUM HOSE L = 26"	1
22	NB.52.101	1 13/16 X 2 3/4 S/S WORM DRIVE CLAMP	1
23	AIW.14X4.CRD	CORD 14 GA 4 CONNECTOR 48IN	1
24	SAS.CS.8165C	TURN-LOCK CONNECTOR 460V	1
25	AIW.14X4.CRD	CORD, 14 GA 4 CONNECTOR 33 IN	1
26	PDG.33026.00	CARABINER, CORD HANGER / PDG3K	1
27	PDG.33025.00	LEVEL, T TYPE / PDG3K	1
28	PDG.32092.00	GRIP, CORD SINGLE EYE / PDG3K EDGER	1

2 A	PDG.80293.00	FASTENING SYSTEM, 1IN STRIP HOOK	43.3 inch
3 A	PDG.32104.00	PLUG, BRASS FITTING 1/4 / PDG3K EDGER	2
12/13 A	PDG.32089.00	FASTENING SYSTEM, 1IN STRIP LOOP	43.5 inch
19 A	NB.11.108	SCREW, HEX FLANGED M6 X 16	1
19 B	NB.20.140	NUT INSERT, M6	1
23 A(#11)	NB.59.101	GRIP, 90 DEGREE	2
23 B	795.00.10	WIRENUT, YELLOW	6
23 C	PDG.32103.00	TERMINAL, RING	1
25 A(#11)	NB.59.101	GRIP, 90 DEGREE	1
25 B	795.10.14	FERRULE, 14 GA	4
25 C	PDG.32102.00	TERMINAL, RING 1/4	4

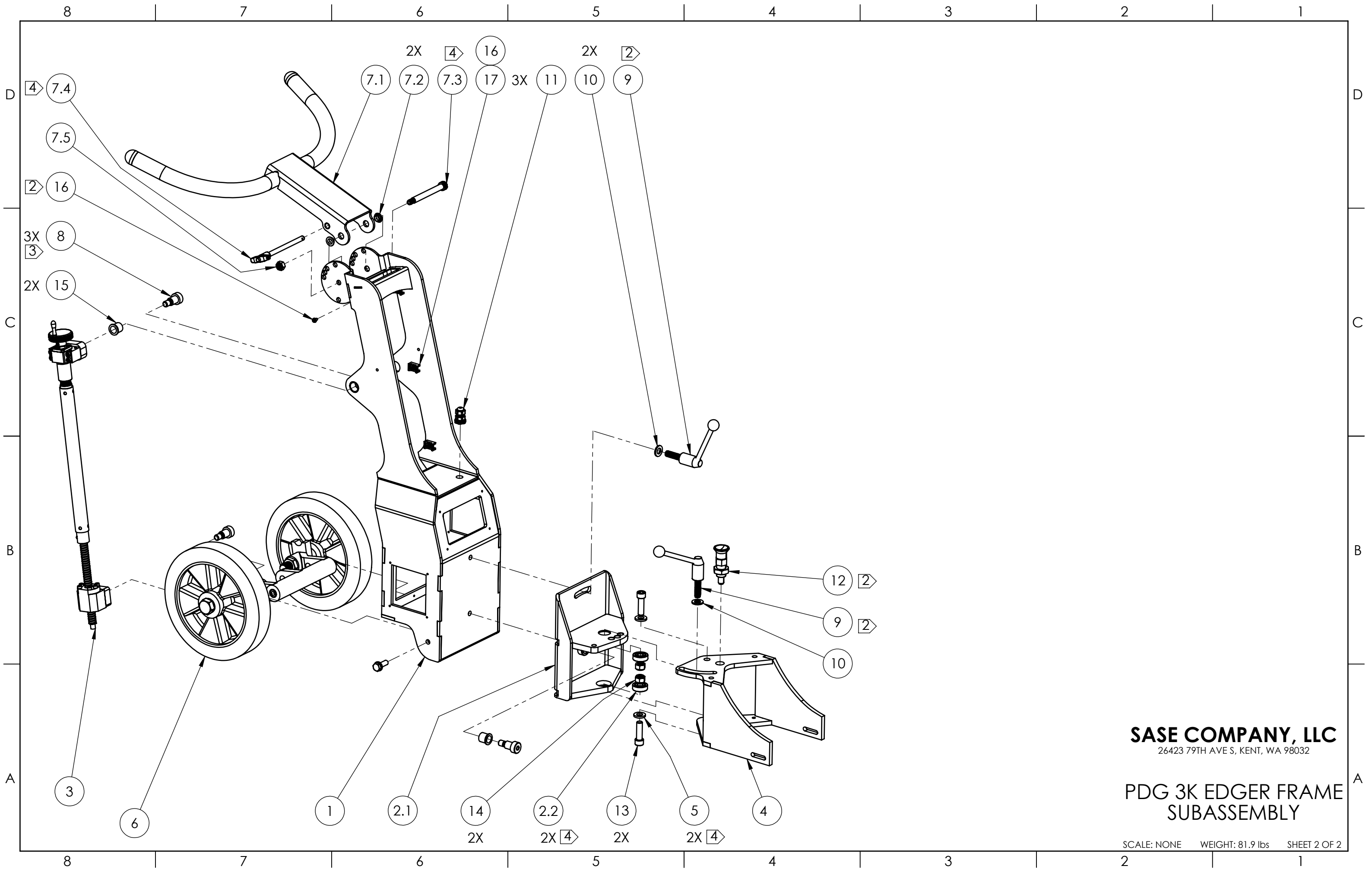

SASE COMPANY, LLC
 26423 79TH AVE S, KENT, WA 98032

**PDG 3K EDGER FRAME
 SUBASSEMBLY**

SCALE: NONE WEIGHT: 81.9 lbs SHEET 2 OF 2

PDG3000 FRAME			
Item No.	Part No.	Description	Qty.
1	PDG.33001.00	PDG 3K EDGER FRAME	1
2	SEE PAGE 12	PDG 3K EDGER TILT PLATE ASSEMBLY	1
2.1	PDG.33002.00	PDG 3K EDGER FRAME TILT PLATE ASSEMBLY	1
2.2	PDG.33023.00	BEARING 6201-2RS	2
3	SEE PAGE 16	PDG 3K EDGER BALL SCREW ASSEMBLY	1
4	PDG.33003.00	PDG 3K EDGER FRAME SWIVEL BRIDGE	1
5	PDG.33011.00	PDG 3K EDGER SWIVEL PIVOT SPACER	2
6	SEE PAGE 14	PDG 3K EDGER WHEEL ASSEMBLY	1
7	SEE PAGE 12	PDG 3K EDGER HANDLEBAR SUBASSEMBLY	1
7.1	PG.33004.00	PDG 3K EDGER HANDLEBAR	1
7.2	PDG.32099.00	IGUS PLASTIC BUSHING	2
7.3	NB.15.255	SCREW, SHOULDER 16MM X 100MM, M12 X 1.75	1
7.4	PDG.32081.00	T-HANDLE QUICK RELEASE PIN W/ LANYARD	1
7.5	NB.20.131	NUT, NYLOC M10 ZINC	1
8	NB.15.253	SCREW, SOCKET HEAD SHOULDER M16 X 20 M12-1.75	3
9	PDG.33022.00	HANDLE, ADJUSTABLE WITH BALL KNOB	2
10	NB.30.154	BRASS FLAT WASHER M12	2
11	NB.59.102	CORD GRIP FOR CONTROLS	1
12	PDG.80150.70	PLUNGER, PULL KNOB	1
13	NB.12.267	SCREW, SOCKET HEAD CAP M12 X 1.75 X 40	2
14	NB.20.118	NUT, HEX M12-1.75 NYLOC	2
15	PDG.33021.00	BEARING, OIL EMBEDDED FLANGED SLEEVE 200D X 16 ID	2
16	NB.11.107	SCREW, FLANGED SOCKET HEAD CAP M4-0.7 X 8 ZINC	4
17	NB.52.201	ZIPTIE MOUNT	3

PDG3000 FRAME NOTES

- ② APPLY THREAD LOCKER (RED LOCTITE #263).
- ③ APPLY THREAD LOCKER (RED LOCTITE #263) PRIOR TO INSTALLATION AND TORQUE TO 35 FT-LBS.
- ④ APPLY GREASE PRIOR TO INSTALLATION.

8 7 6 5 4 3 2 1

D

D

C

C

B

B

A

A

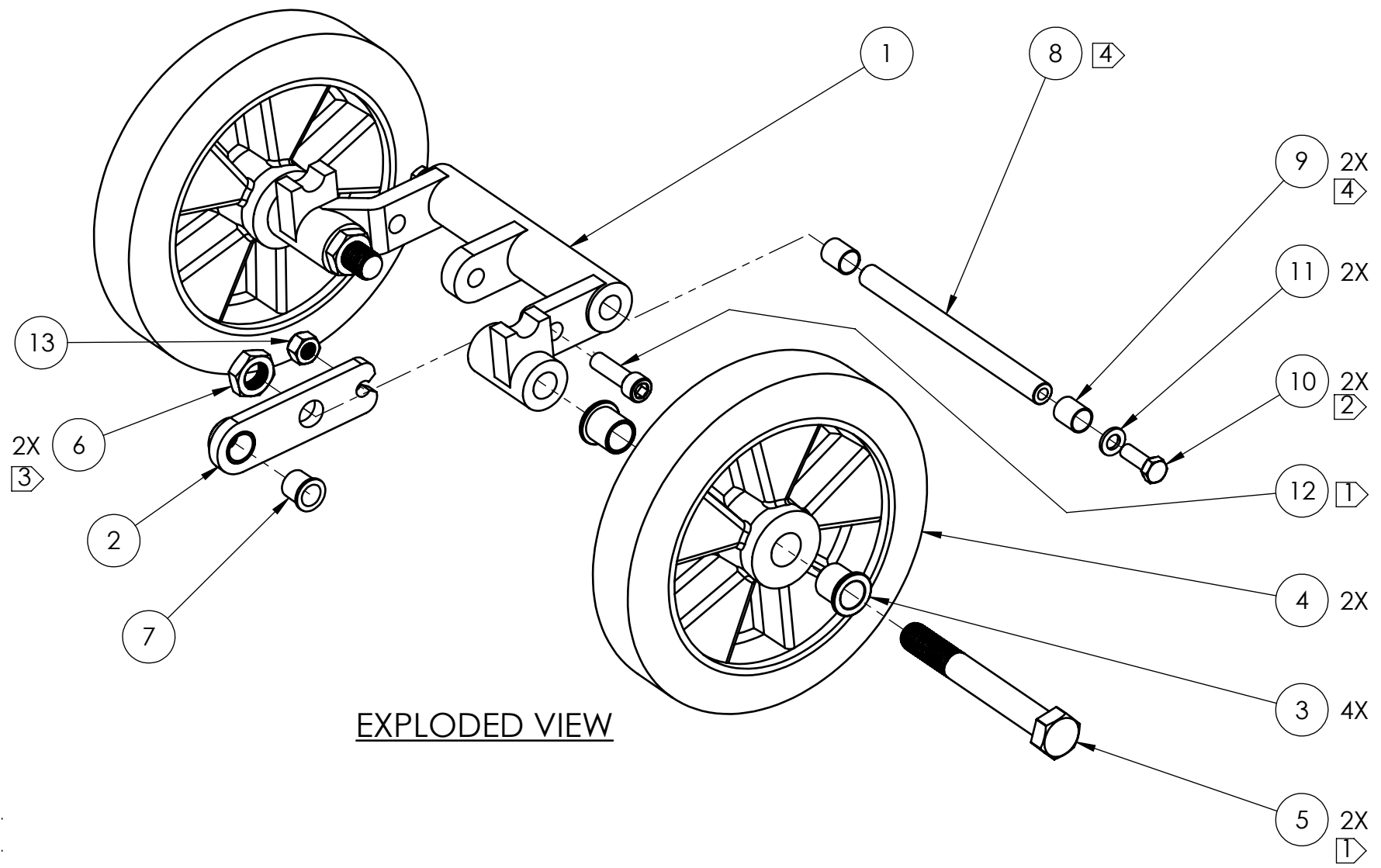

EXPLODED VIEW

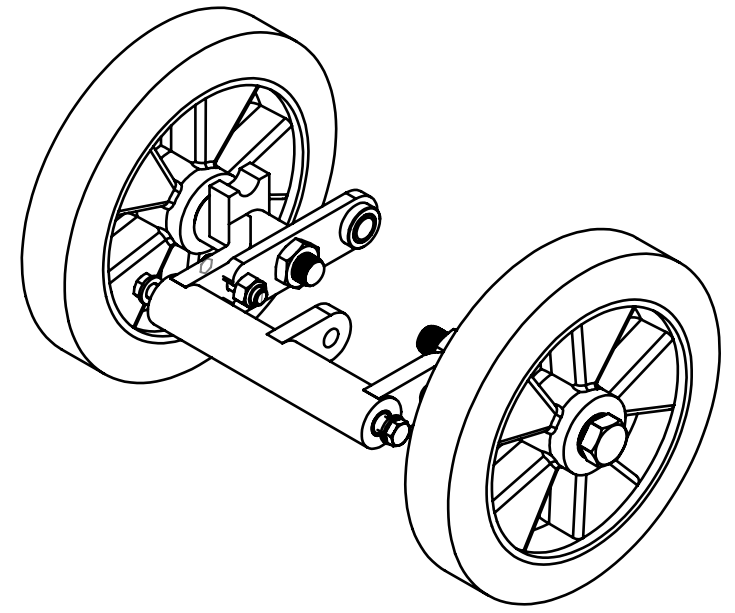

ISOMETRIC VIEW
(P/N: PDG.33012.03)

SASE COMPANY, LLC
26423 79TH AVE S, KENT, WA 98032

TITLE:
PDG 3K EDGER WHEEL ASSEMBLY

SCALE: NONE WEIGHT: 14.9 lbs SHEET 1 OF 1

8 7 6 5 4 3 2 1

PDG3000 WHEEL			
Item No.	Part No.	Description	Qty.
1	SC.10.801	MOUNT, AXLE	1
2	PDG.33012.00	PDG 3K EDGER SWINGARM LINK	1
3	PDG.20255.60	AXLE BUSHING 5K	4
4	PDG.45077.00	PDG5000 WHEEL	2
5	NB.10.253	SCREW, HEX M20-2.5 X 160 ZINC	2
6	NB.20.110	NUT, JAM M20 - 2.5	2
7	PDG.33021.00	BEARING, OIL EMBEDDED FLANGED SLEEVE 200D X 16 ID	1
8	SC.10.802	AXLE, BRACKET	1
9	SC.10.805	BUSHING, MB 1620 DU	2
10	NB.10.136	SCREW, HEX M10-1.5 X 30	2
11	NB.30.110	WASHER, FLAT M10 ZINC	2
12	NB.12.267	SCREW, SOCKET HEAD CAP M12 X 1.75 X 40	1
13	NB.20.118	NUT, HEX M12-1.75 NYLOC	1

PDG3000 WHEEL NOTES

- ① APPLY THREAD LOCKER (RED LOCTITE #263).
- ② APPLY THREAD LOCKER (BLUE LOCTITE #243).
- ③ TORQUE TO 35 FT-LBS.
- ④ APPLY GREASE PRIOR TO INSTALLATION.

8

7

6

5

4

3

2

1

D

D

C

C

B

B

A

A

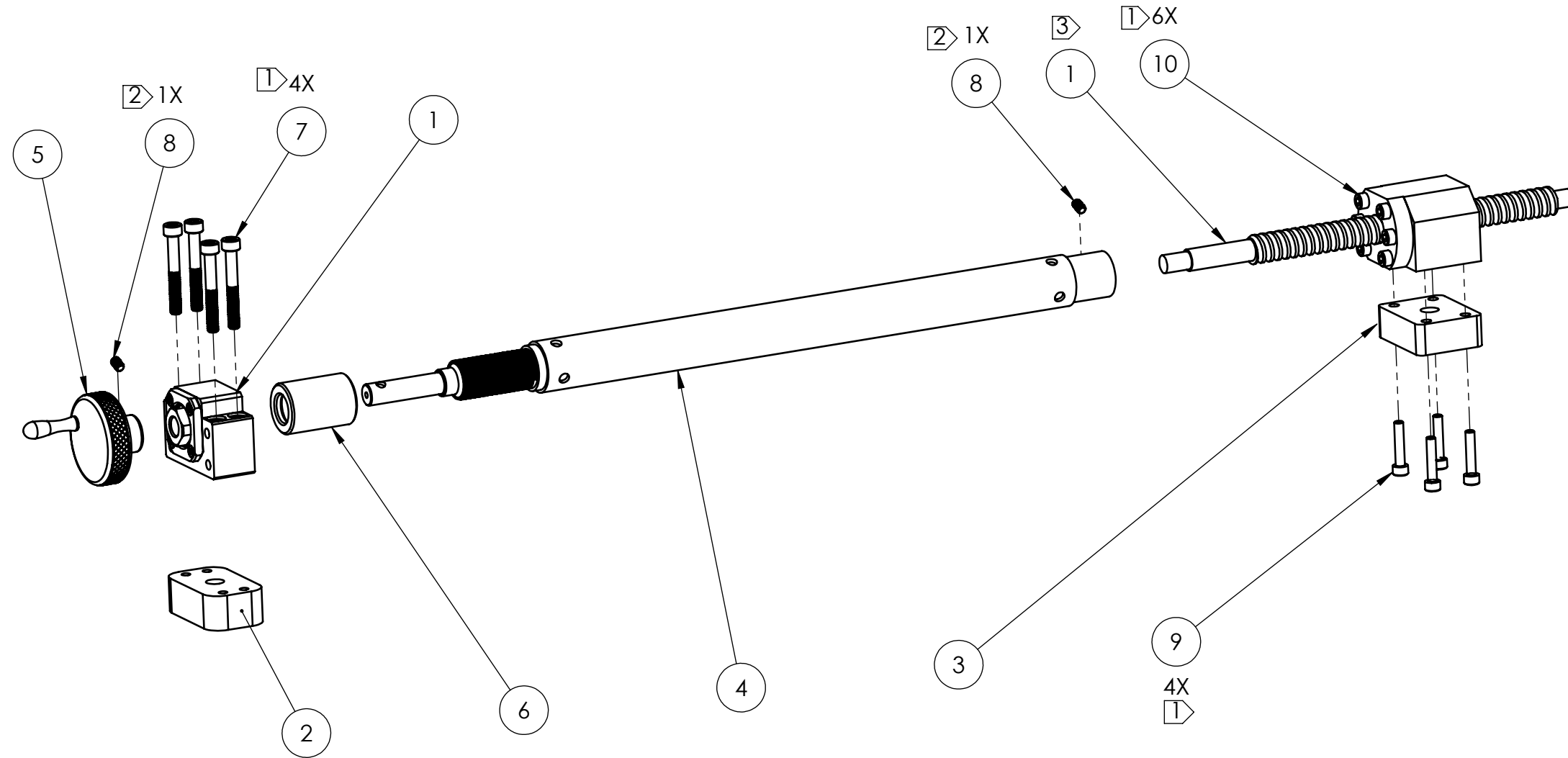

NOTES:

- ① APPLY THREAD LOCKER (RED LOCTITE #263).
- ② APPLY THREAD LOCKER (BLUE LOCTITE #243).
- ③ APPLY GREASE.

EXPLODED VIEW
PDG.33005.00

SASE COMPANY, LLC
26423 79TH AVE S, KENT, WA 98032

TITLE:

**PDG 3K EDGER BALL
SCREW ASSEMBLY**

SCALE: NONE WEIGHT: 3.1 lbs SHEET 1 OF 1

8

7

6

5

4

3

2

1

PDG3000 BALL SCREW

Item No.	Part No.	Description	Qty.
1	PDG.33015.00	BALL SCREW ASSEMBLY	1
2	PDG.33006.00	PDG 3K EDGER BALL SCREW TOP ANCHOR	1
3	PDG.33008.00	PDG 3K EDGER BALL SCREW BOTTOM ANCHOR	1
4	PDG.33007.00	PDG 3K EDGER BALL SCREW ROD WELDMENT	1
5	PDG.33020.00	KNURLED-RIM KNOB	1
6	PDG.33009.00	PDG 3K EDGER BALL SCREW BRAKE KNOB	1
7	NB.12.124	SCREW, SOCKET HEAD M6 X 45	8
8	NB.18.146	SET SCREW, M5-.8 X 8 FLAT TIP	2
9	NB.12.092	SCREW, SOCKET HEAD CAP M5-0.8 X 25	4
10	NB.12.091	SCREW, SOCKET HEAD CAP M5-0.8 X 20	6
11	NB.12.088	SCREW, SOCKET HEAD CAP M4-0.7 X 20	6

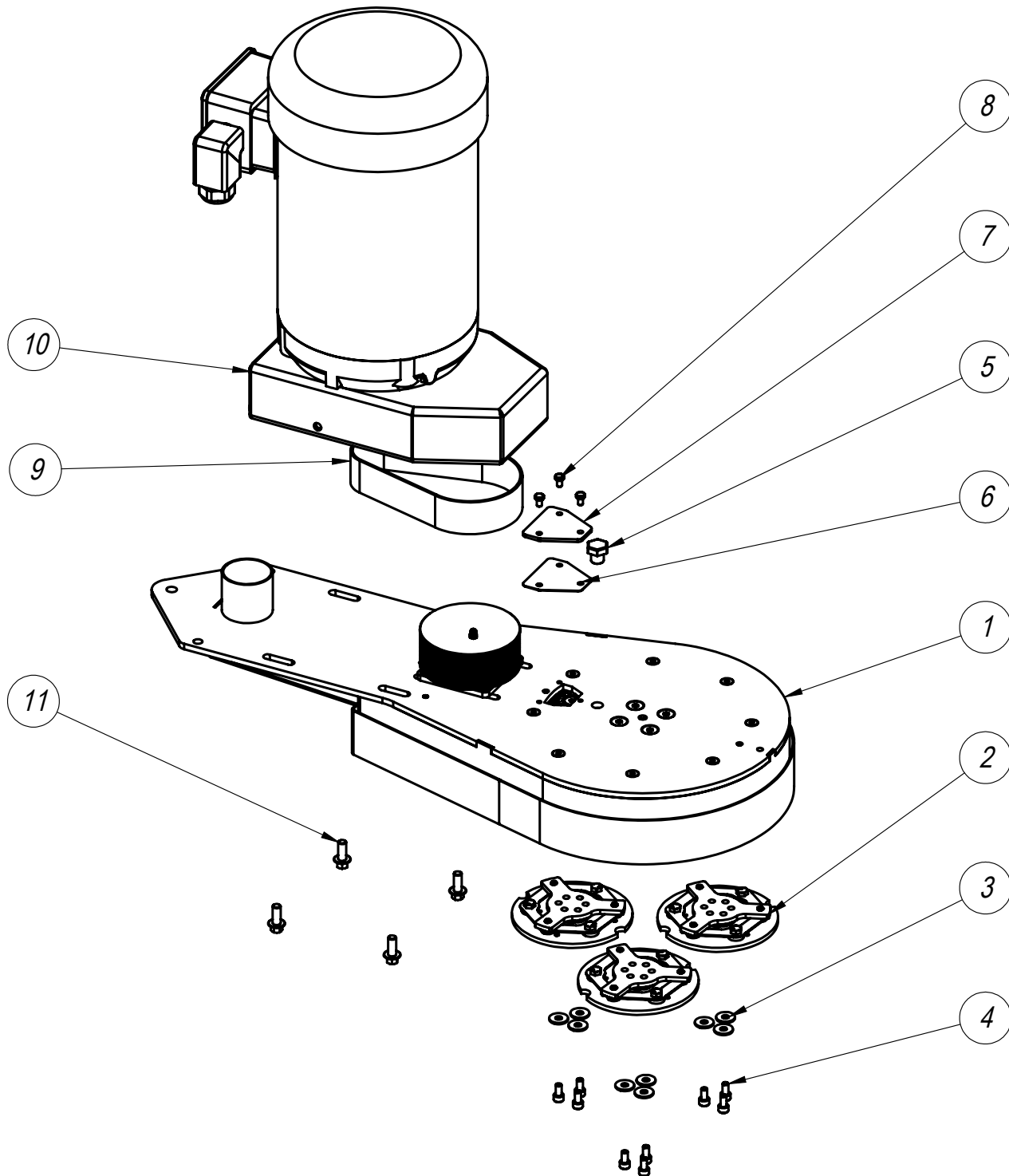

MOTOR WIRING:

MOTOR REQUIRES 4 FEET OF 14/4 AWG WITH NB.52.201 ON EACH END BOTH WITH LEADS
 LEADS:1 RED U / 2 WHITE V / 3 BLACK W
 PDG.32102.00 X3; to inverter > Motor-Out
 (795.00.30 1/2 inch on each)
 PDG.32103.00 X1; to inverter > ground
 (795.00.30 1/2 inch on each)
 PDG.32103.00 X1; to motor > ground
 (795.00.30 1/2 inch on each)
 230 V USES 6 795.00.10 WIRE NUT YELLOW
 460 V USES 4 795.00.10 WIRE NUT YELLOW

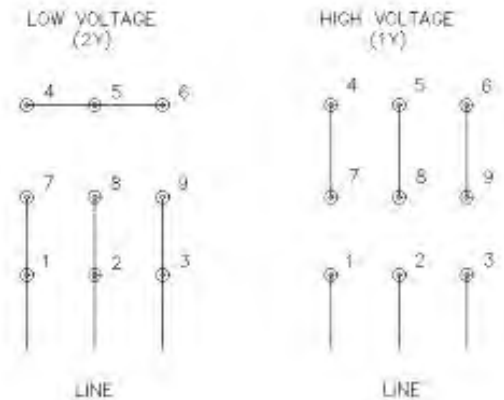

POWER-IN WIRE:

REQUIRES 3 FEET OF 14/4 AWG WITH PDG.32090.00 AND LEADS ON ONE END AND A PLUG ON THE OTHER.
 LEADS:1 RED L1 / 2 WHITE L2 / 3 BLACK L3
 230V USES SAS.CS8365C PLUG
 460V USES SAS.CS8165C PLUG
 PLUG:1 RED X / 2 WHITE Y / 3 BLACK Z
 PDG.32102.00 X3; to inverter > Power-In
 (795.00.30 1/2 inch on each)
 PDG.32103.00 X1; to inverter > ground
 (795.00.30 1/2 inch on each)

PDG 3000

Upper Box on Carriage

SCALE: 1:6 | WEIGHT: 109.40 | SHEET 4 OF 4

Upper Box on Carriage

Item No.	Part No.	Description	Quantity
1	Pages 26-27	GRIND HEAD ASSEMBLY	1
2	Pages 30-31	FLEX HEADS	3
3	NB.30.214	WASHER, LOCK M6	9
4	NB.12.108	SCREW, SOCKET HEAD CAP M6 -1.0 X 12 ZINC	9
5	PDG.32055.00	BREATHER	1
6	PDG.32096.00	GASKET, GEAR ACCESS COVER	1
7	PDG.32022.00	COVER, GEAR ACCESS	1
8	NB.11.104	SCREW, FLANGED 5M - 0.8 x8	3
9	PDG.32046.00	BELT, POLY-V 180J16	1
10	Pages 20-21	MOTOR SET-UP	1
11	NB.11.123	SCREW, FLANGED HEX HEAD CAP M8-1.25 X 20 NON-SERRATED ZINC	4

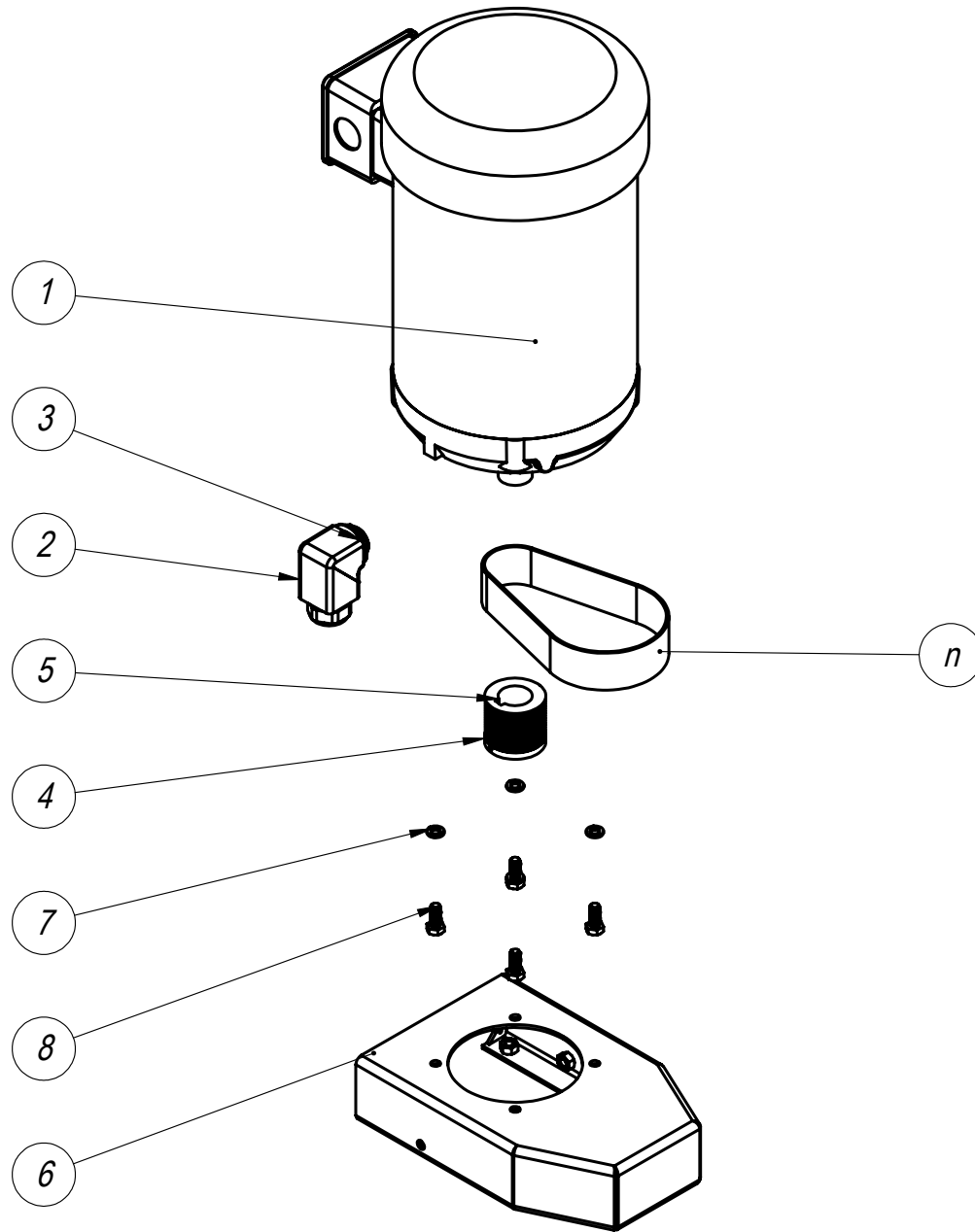

PDG 3000		
PLANETARY EDGER HEAD W/MOTOR		
SCALE: 1:6	WEIGHT: 109.38	SHEET 2 OF 2

MOTOR SET-UP			
Item No.	Part No.	Description	Quantity
1	PDG.32061.00	MOTOR	1
2	NB.59.101	GRIP, CORD CONNECTOR 90 MALE 0.50-0.63	1
3	NB.20.146	NUT, 3/4" METAL CONDUIT LOCK	1
4	NB.18.141	SET SCREW, M5 .8 X 8 CUP POINT	1
5	PDG.32021.00	SHEAVE, MOTOR	1
6	PDG.32025.00	HOUSING, UPPER BELT	1
7	NB.30.212	WASHER, LOCK M8 ZINC	4
8	NB.10.114	SCREW, HEX M8 X 20 ZINC	4

INVERTER TO MOTOR WIRING			
2b	AIW.14X4.CRD	CORD, POWER 14/4	3 FT
2c	PDG.32102.00	RING, TERMINAL 12-10 AWG #6 (terminals for VFD)	6
2d	795.00.23	HEAT SHRINK TUBING	~ 3 IN
2e	PDG.32103.00	RING, TERMINAL 12-14 AWG #10 (ground in Motor)	1
2f	795.00.10	10-18 TWIST YELLOW NYLON (terminals for motor)	3
2g	PDG.32112.00	12-10 AWG RING-#10 (ground in VFD)	1
n	PDG.32046.00	BELT, POLY-V 180J16 (LISTED TWICE)	1

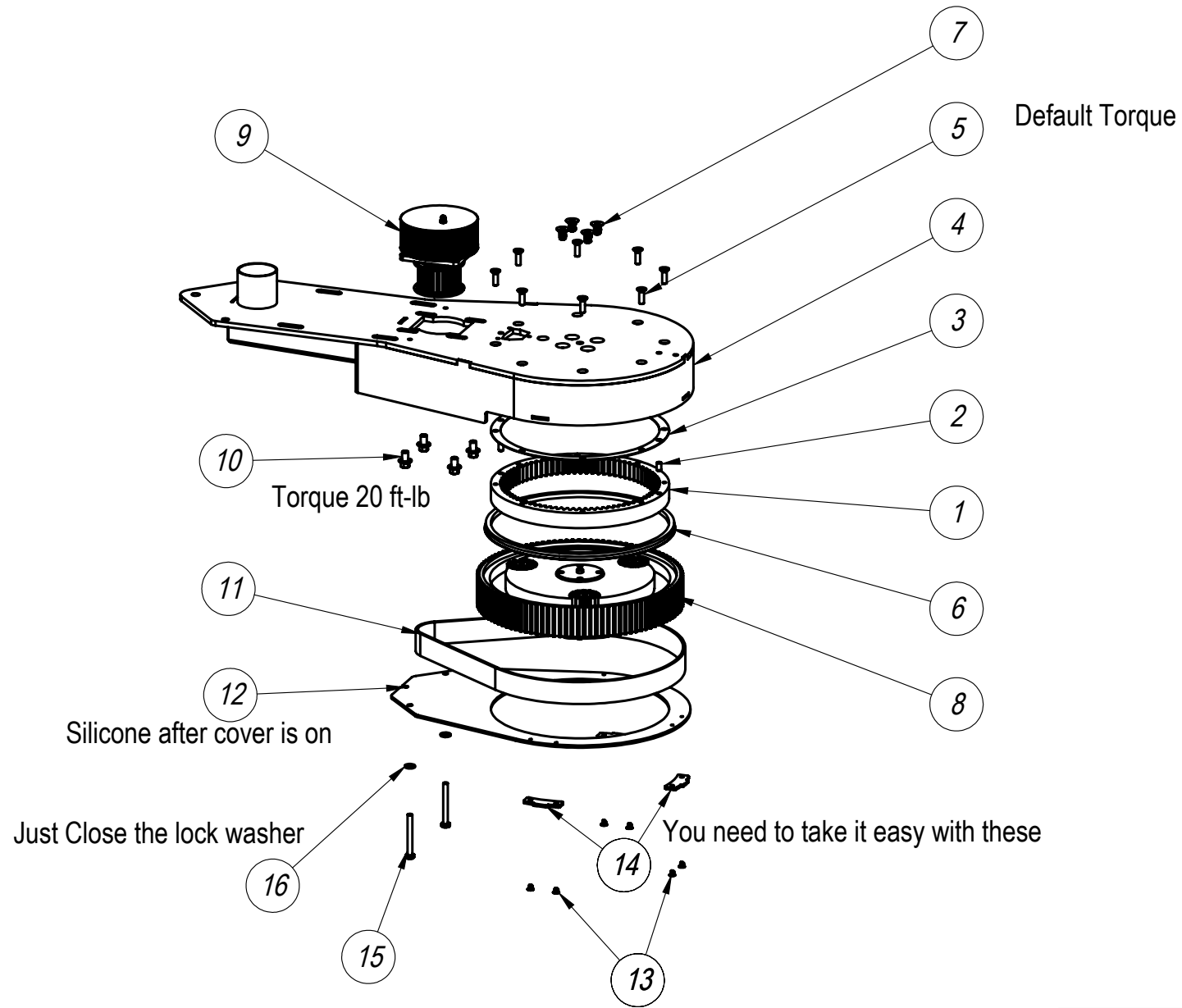

PDG 3000

GRIND HEAD ASSEMBLY

SCALE: 1:8 | WEIGHT: 108.77 | SHEET 1 OF 7

GRIND HEAD ASSEMBLY

Item No.	Part No.	Description	Quantity
1	PDG.32005.00	GEAR, RING	1
2	NB.50.155	PIN, DOWEL M6 X 10MM	2
3	PDG.32095.00	GASKET, RING GEAR	1
4	PDG.32064.00	CARRIAGE, WELDED FRAME PART	1
5	NB.13.116	SCREW, FLAT HEAD TORX SOCKET CAP M6 -1.0 X 20	8
6	PDG.32060.00	SEAL, V-RING 220 VL R	1
7	NB.13.214	SCREW, FLAT HEAD SOCKET CAP M8-1.25 X 14 10.9 ZINC	4
8	Pages 26-27	CARRIER SET-UP	1
9	Pages 24-25	TRANSFER SHAFT ASSEMBLY	1
10	NB.11.119	SCREW, FLANGED HEX HEAD CAP M8-1.25 X 12 NON-SERRATED ZINC	4
11	PDG.32047.00	BELT, 960-8MGT-30	1
12	PDG.32015.00	COVER, DRUM	1
12 b	PDG.32088.00	FELT, (NOT DISPLAYED, MUST BE IN PLACE, AND GREASED BEFORE 12 CAN BE INSTALLED)	3 Ft
13	NB.13.110	SCREW, FLAT HEAD SOCKET CAP M4 -0.7 X 6 10.9 BLACK	6
14	PDG.32016.00	TAB, DRUM COVER LOCK	3
15	NB.10.145	SCREW, HEX M6 X 1.0 X 55	2
16	NB.30.214	WASHER, LOCK M6	2

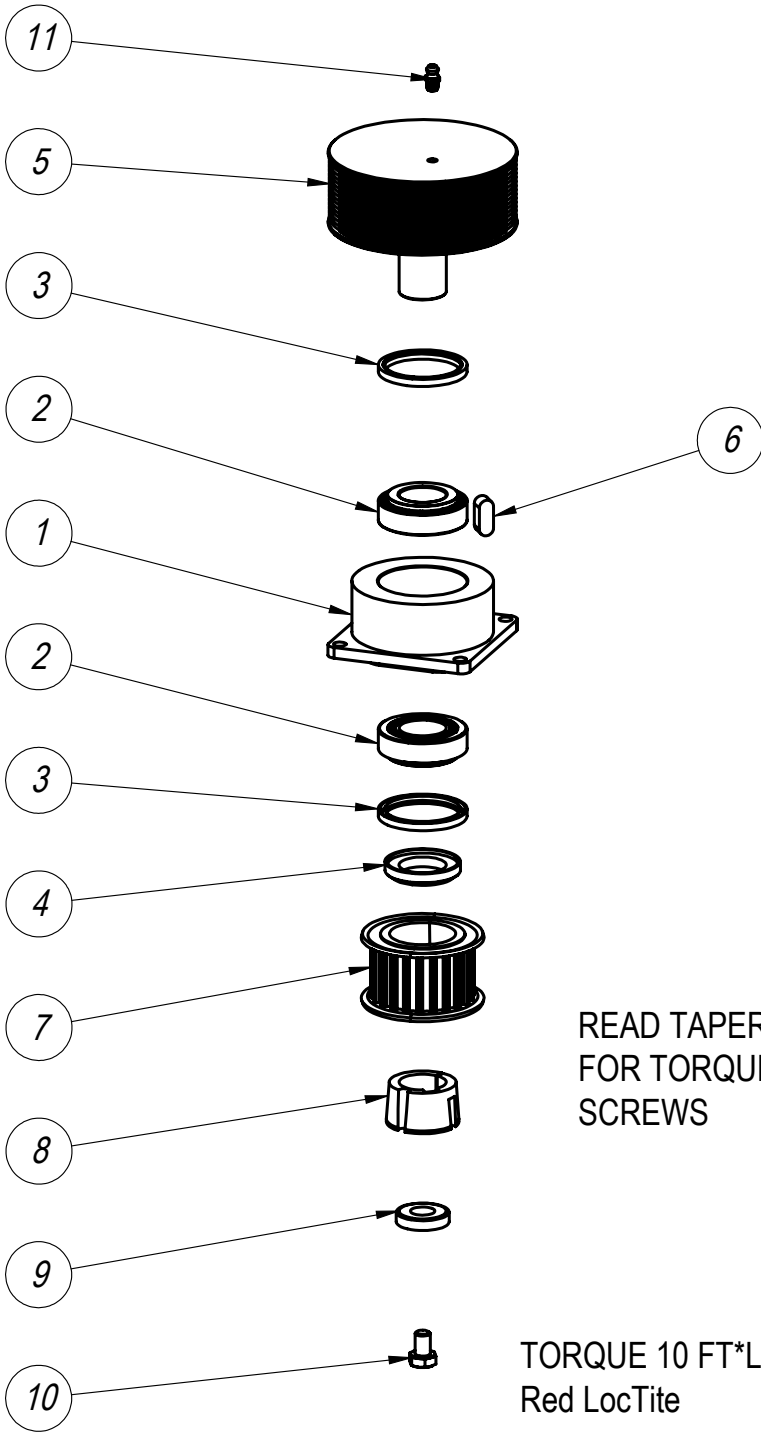

READ TAPER LOCK INSTRUCTIONS
FOR TORQUE PROCESS OF SET
SCREWS

TORQUE 10 FT*LB
Red LocTite



PDG 3000		
TRANSFER SHAFT ASSEMBLY		
SCALE: 3:7	WEIGHT: 2.83	SHEET 1 OF 1

TRANSFER SHAFT

Item No.	Part No.	Description	Quantity
1	PDG.32017.10	HOUSING, TRANSFER SHAFT BEARING	1
2	PDG.32043.00	BEARING, 32005X	2
3	PDG.32048.00	SEAL, 40 X 47 X 4	2
4	PDG.32019.10	RING, IDLER SHAFT SPACER	1
5	PDG.32018.10	SHAFT, TRANSFER	1
6	NB.70.123	KEY, SQUARE M8 X 20	1
7	PDG.32044.00	SPROCKET, P22-8MGT-30-1108	1
8	PDG.32045.00	BUSHING, TAPER LOCK 1108 25MM	1
9	PDG.32020.00	RETAINER, IDLER SHAFT	1
10	NB.10.152	SCREW, HEX HEAD M12-1.25 X 25	1
11	DG.1426	FITTING, GREASE STRIGHT M6	1
11b	NB.10.200	SCREW, HEX HEAD M6 X 12	1

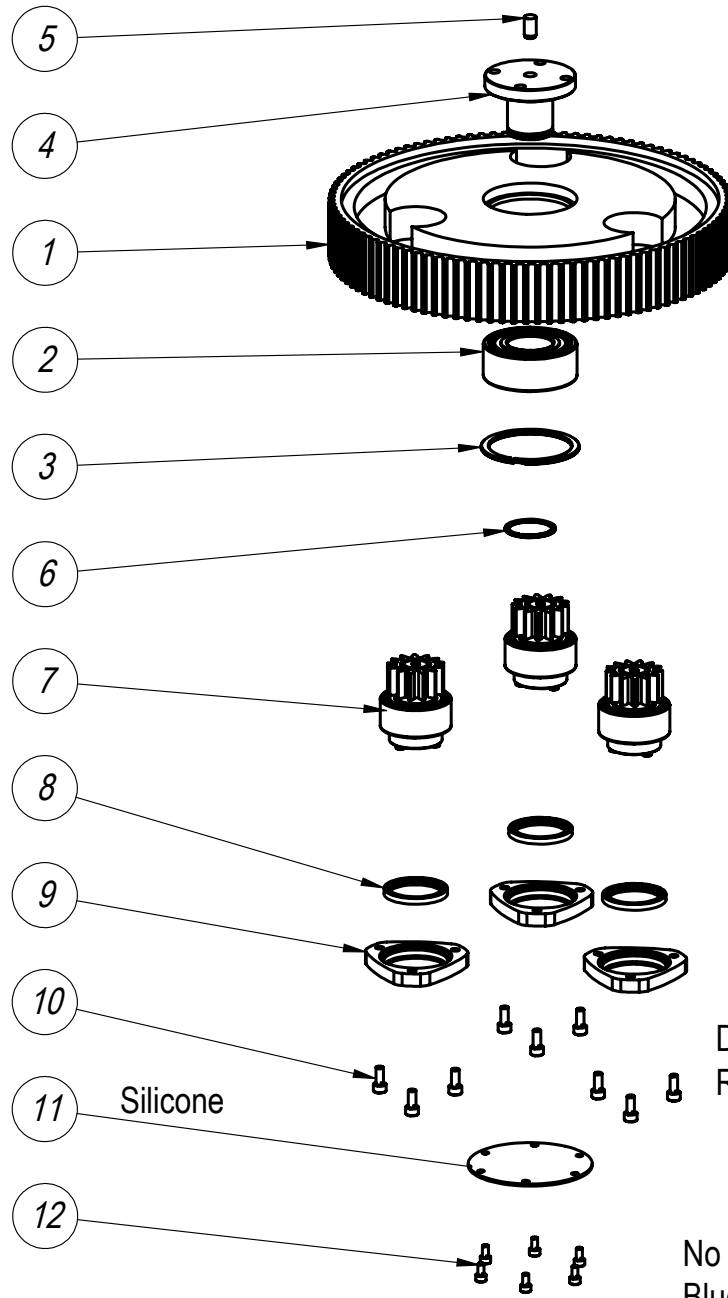

PDG 3000		
CARRIER ASSEMBLY		
SCALE: 1:5	WEIGHT: 14.62	SHEET 1 OF 1

CARRIER ASSEMBLY

Item No.	Part No.	Description	Quantity
1	PDG.32003.00	CARRIER	1
2	PDG.32041.00	BEARING, 3206	1
3	PDG.32007.01	SPACER, STATIONARY BEARING (NO LONGER A RETAINING RING AS SHOWN)	1
4	PDG.32004.00	SPINDLE, STATIONARY	1
5	NB.50.157	PIN, DOWEL M8 X 16MM	1
6	NB.40.134	RING, SMALLEY EXTERNAL RETAINING M30	1
7	Pages 28-29	PLANETARY ASSEMBLY	3
8	PDG.32042.00	SEAL, 35 X 42 X 4	3
9	PDG.32006.00	COVER, SLURRY	3
10	NB.12.089	SCREW, SOCKET HEAD CAP M5 -0.8 X 12	9
11	PDG.32007.00	COVER, SPINDLE	1
12	NB.12.086	SCREW, SOCKET HEAD CAP M4 -0.7 X 10	6

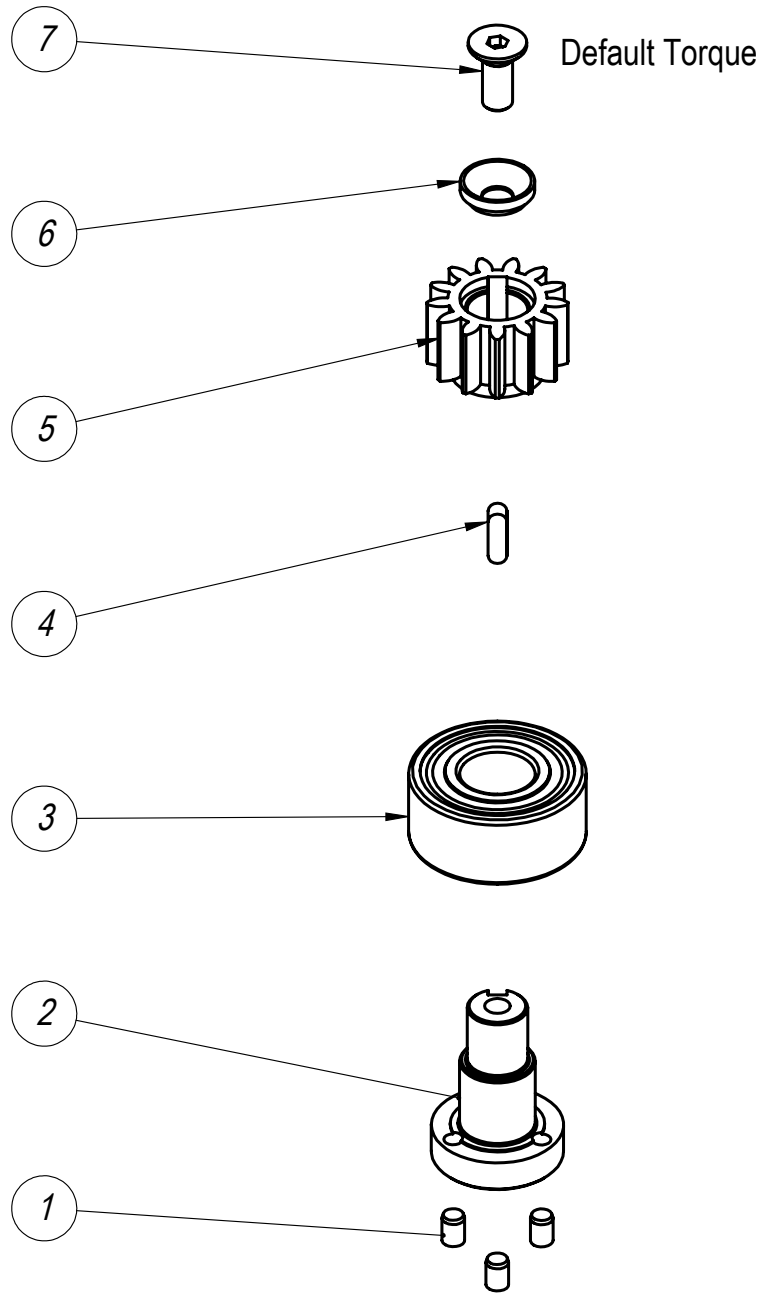

PDG 3000

**PLANETARY
ASSEMBLY**

SCALE: 1:5 | WEIGHT: 0.39 | SHEET 1 OF 1

PLANETARY ASSEMBLY

Item No.	Part No.	Description	Quantity
1	NB.50.155	PIN, DOWEL M6 X 10MM	9
2	PDG.32000.00	AXLE, PLANETARY	3
3	PDG.32040.00	BEARING, 3204	3
4	NB.70.122	KEY, SQUARE M5 X 16	3
5	PDG.32001.00	GEAR	3
6	PDG.32002.00	RETAINER	3
7	NB.13.218	SCREW, FLAT HEAD SOCKET CAP M8 -1.25 X 20	3

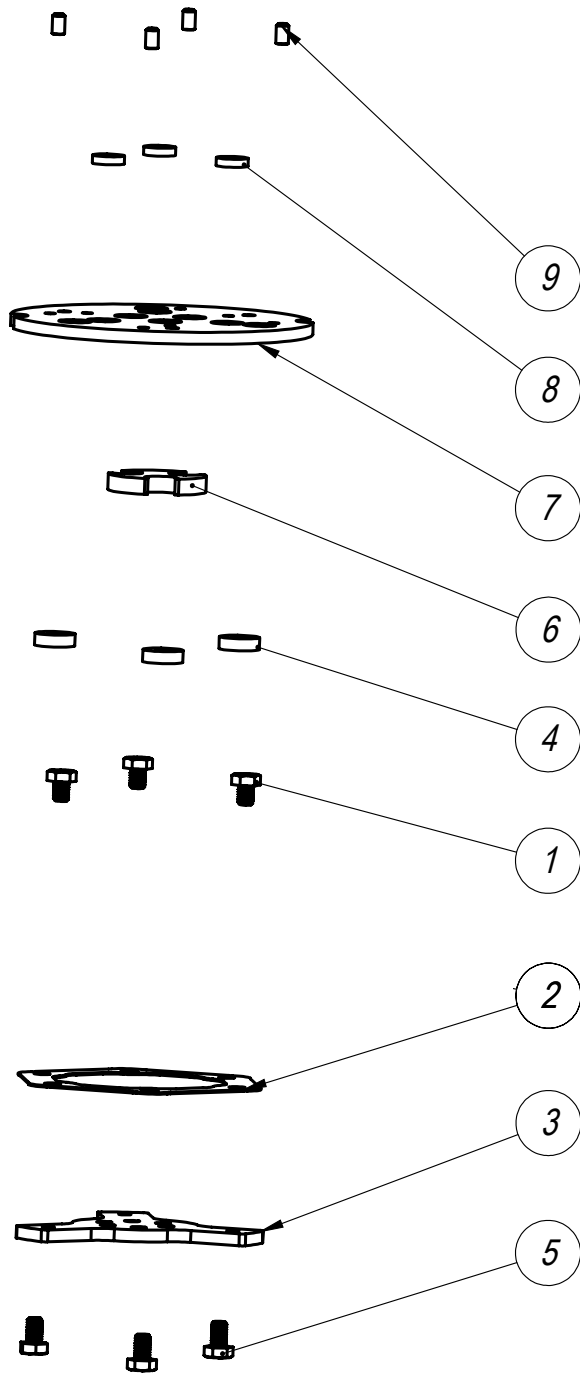

*DRIVING PLATE
FASTENS TO SPRINGS*

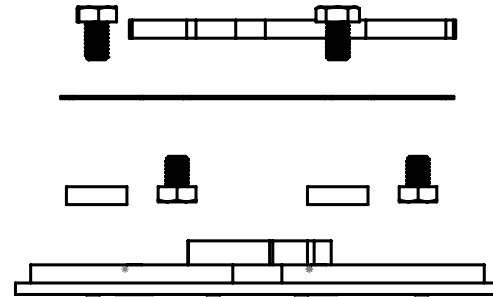

*DRIVING PLATE AND SPRINGS
FASTEN TO DRIVEN PLATE W/PINS*

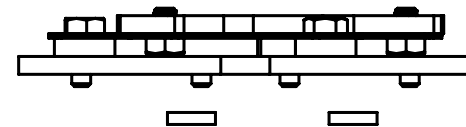

REQUIRES 3 SETS

PDG 3000

**FLEX HEAD
ASSEMBLY**

SCALE: 1:10 WEIGHT: 0.87

SHEET 1 OF 1

FLEX HEAD ASSEMBLY

Item No.	Part No.	Description	Quantity
1	NB.10.141	SCREW, HEX M6 X 8	3
2	PDG.32010.20	SPRING, TI	1
3	PDG.32008.00	PLATE, DRIVING	1
4	PDG.32012.00	STANCHION, FLEX HEAD	3
5	NB.10.142	SCREW, HEX M6 X 10	3
6	PDG.32011.00	BUMPER, FLEX HEAD	1
7	PDG.32009.00	PLATE, DRIVEN	1
8	PDG.32059.00	MAGNET	3
9	NB.18.141	SET SCREW, M5 .8 X 8 CUP POINT	4

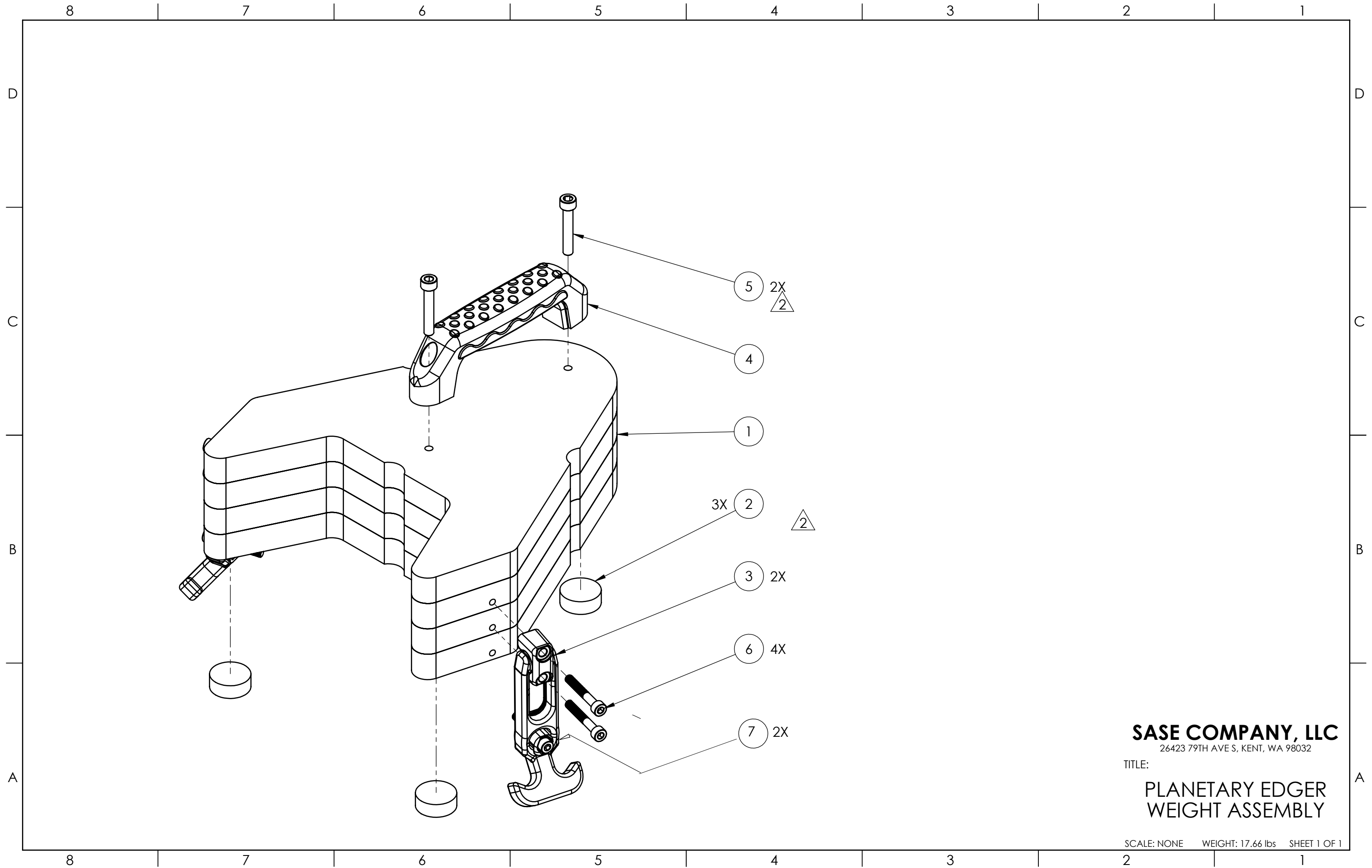

SASE COMPANY, LLC
 26423 79TH AVE S, KENT, WA 98032

TITLE:
**PLANETARY EDGER
 WEIGHT ASSEMBLY**

SCALE: NONE WEIGHT: 17.66 lbs SHEET 1 OF 1

WEIGHT

Item No.	Part No.	Description	Quantity
1	PDG.32062.30	PLANETARY EDGER WEIGHT LAYERED	1
2	PDG.32093.00	PLANETARY EDGER WEIGHT RUBBER RFOOT	3
3	PDG.20274.00	JEEP RUBBER STRAP	2
4	PDG.80134.00	PULL HANDLE	1
5	NB.12.118	SCREW, SOCKET HEAD CAP M6 -1.0 X 35 ZINC	2
6	NB.12.095	SCREW, SOCKET HEAD CAP M5 -1.0 X 35 ZINC	4
7	NB.12.092	SCREW, SOCKET HEAD CAP M5 -1.0 X 25 ZINC (PUT ON GRIND HEAD)	2

230V TRIM POTS

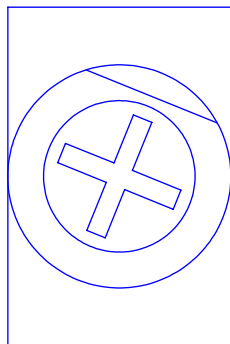

CL

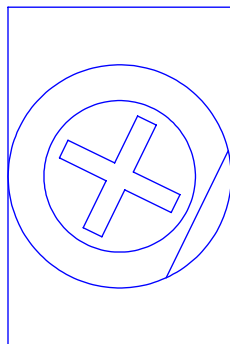

MAX

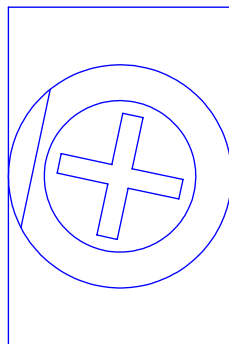

MIN

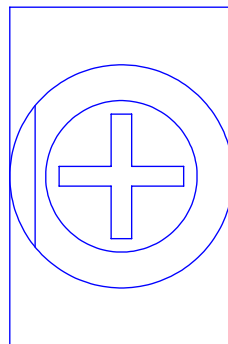

DEC/B

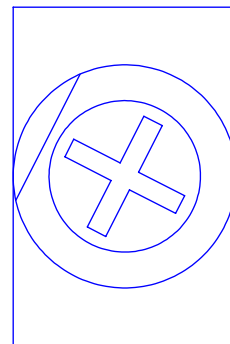

ACC

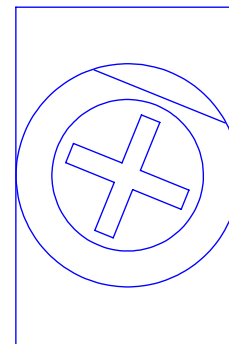

COMP

460V TRIM POTS

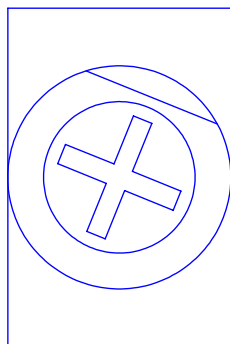

CL

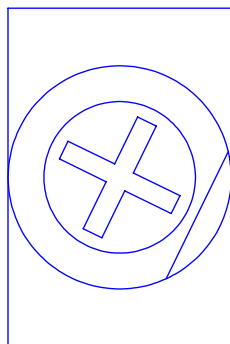

MAX

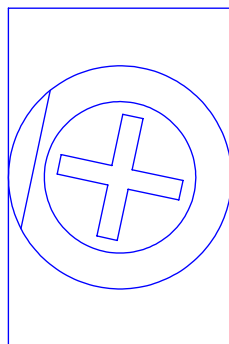

MIN

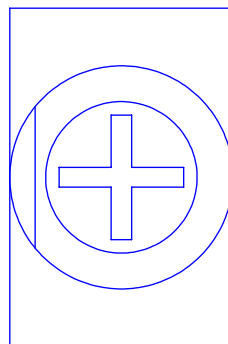

DEC/B

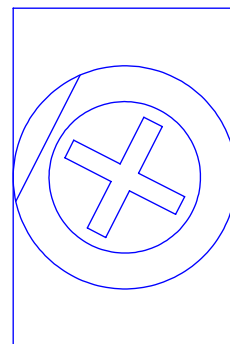

ACC

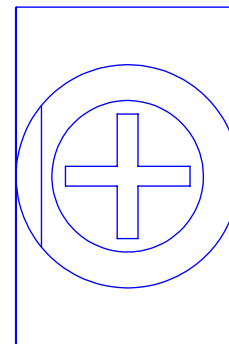

COMP

SASE COMPANY Inc.

EDGER

CONTROLLER SETTINGS

5



4

3

2

1



MANUFACTURER'S WARRANTY POLICY

Included in this warranty are the following pieces of equipment:

Planetary Diamond Grinders: PDG 8000, PDG 6000, PDG 5000, PDG 3000, Edge Pro 180

Dust Extractors: Bull 1250, Bull 300, Bull 45

Scarifiers: SC12E, SC10E, SC8E

Our Commitment to our customer:

SASE Company ("SASE") equipment is warranted to be free of defects in workmanship and materials for a period of one (1) year from original date of purchase. In the event that you should have a claim SASE shall repair, replace or remedy the defective parts resulting from the faulty design, materials or workmanship. Note: This warranty is only valid for equipment either sold by SASE or by an authorized wholesaler or distributor.

Limitations:

- Warranty does not apply to cosmetic damage, damage due to lightning, electrical surges, fire, flood, or other acts of God, accident, misuse, abuse, repair or alteration by other than factory service (unless service center was approved in writing by SASE), negligence, or improper or neglected maintenance as recommended by SASE.
- Common wear parts, such as belts, bearings, seals, filters, dust skirts, wheels, etc., are exempt from warranty.
- SASE is not responsible for loss of income or down time as a result faulty design, materials or workmanship.
- Warranty coverage is valid once a warranty registration card is filled out and returned to SASE.
- A \$100 labor charge may be assessed on the items returned for warranty repair in which no fault is found. Freight charges and associated fees will then become the responsibility of the customer in such an instance.
- Damages which are caused during transportation are not covered under warranty. Such damage claims should be filed with the freight carrier.

Claims:

In the unlikely event that you should experience a defect please contact your SASE representative or a SASE service technician by calling 1.800.522.2606. Please have all pertinent information readily available such as, invoice with date of purchase, model and serial number, and an explanation of the issue. SASE will respond immediately with a corrective action.

Freight responsibility for approved warranty claims:

If the piece of equipment was purchased within 90 days of warranty claim, SASE will arrange for ground freight and will assume all ground freight charges to send the customer the parts required or to send the equipment to an authorized SASE repair center. This includes inbound and outbound ground freight and all fees (duties, fuel surcharges) associated with the shipment.

If the piece of equipment was purchased beyond 90 days and prior to one (1) year of warranty claim, SASE will cover 50% of all ground freight charges, including inbound and outbound freight and all fees (duties, fuel surcharges) associated with the shipment.



PRODUCT & WARRANTY REGISTRATION

WARRANTY IS VOID IF NOT RETURNED AND REGISTERED WITH SASE WITHIN 30 DAYS OF PURCHASE

COMPANY _____

NAME AND TITLE _____

STREET ADDRESS _____

CITY _____ STATE _____ ZIP _____ COUNTRY _____

PHONE _____ EMAIL _____

DATE OF PURCHASE _____ SERIAL NUMBER _____

INVOICE NUMBER OF PURCHASE _____

PDG 8000 PDG 6000 PDG 5000 PDG3000 Edge Pro180

SC08E SC10E SC12E BULL 1250 BULL 300 BULL 45

PLEASE FILL OUT IN FULL AND SUBMIT TO: SASE COMPANY 2475 STOCK CREEK BLVD
ROCKFORD TN, 37853 FAX: 865.745.4110 EMAIL: JohnA@SASECompany.com

QUESTIONS? CALL 800.522.2606